



Flush-mount multifunction display unit ATE 310

KEY POINTS

- Alternating display of 1 to 3 parameters
- 3 audible and visual alarms
- Configuration keyboard and acknowledgment of the alarm on the front face
- 3 analogue inputs 0-5/10 V or 0/4-20 mA
- Ethernet communication (option)
- RS485 MODBUS protocol communication
- 30 pre-programmed units and configurable units
- Front face made of brushed stainless steel with electroluminescent display

FEATURES OF THE HOUSING

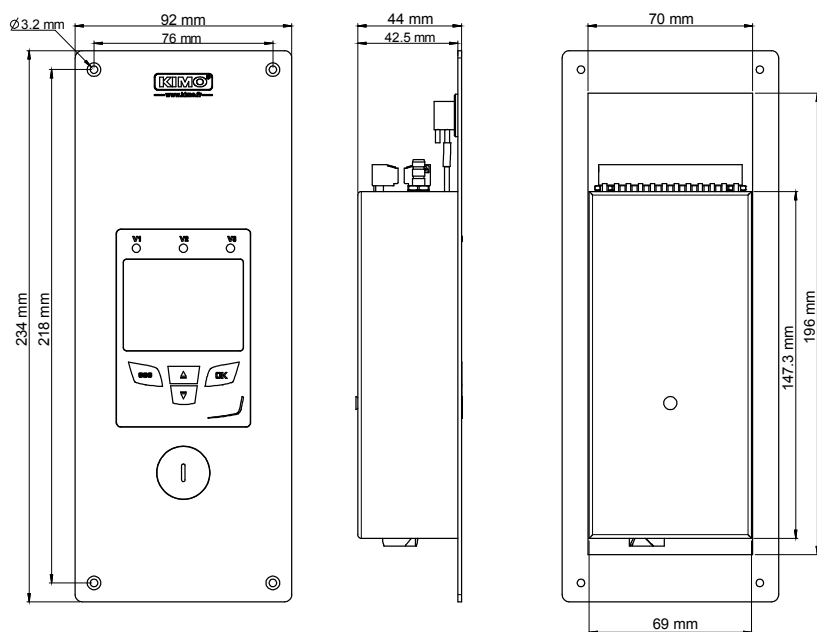

Front face

Brushed stainless steel 316 L

Back housing

Flush-mount in stainless steel 304 L

Protection

IP65 in front face

Weight

585 g

DISPLAY FEATURES

Display	Electroluminescent alphanumeric (38 x 48 mm). Protection glass in red inactinic PMMA .
First line (measurement)	4 digits of 8 segments each. Size: 14 x 48 mm.
Second line (unit)	4 digits of 14 segments each. Size: 14 x 48 mm.
Comma position	Configurable: 0 / 0.0 / 0.00
Value of the measurement	From -9.99 to 99.99 and from -999 to 999
Accuracy*	±0.1% of reading ±1 digit
Number of channels	From 1 to 3 ways alternating
Location of channels	By red Led V1, V2 and V3
Available units	30 pre-programmed units (see table) and configurable units
Response time	< 1 second

*All accuracies indicated in this document were stated in laboratory conditions and can be guaranteed for measurements carried out in the same conditions, or carried out with calibration compensation.

TECHNICAL SPECIFICATIONS

Power supply	24 Vac / Vdc $\pm 10\%$ Be careful, risk of electric shock 
Inputs	3 x 0/4-20 mA or 3 x 0-5/10 V; Common mode voltage < 30 Vac; Input impedance: 100 Ohm
Galvanic isolation	Between input and power supply
Consumption	4.32 VA
European directives	2014/30/UE EMC; 2014/35/UE Low voltage; 2011/65/EU RoHS II; 2012/19/UE WEEE
Electrical connection	Screw terminal block for cables from 0.05 to 1.5 mm ² or from 30 to 16 AWG. Carried out according to the code of good practice.
RS485 communication	Digital: Modbus RTU protocol, configurable communication speed from 2400 to 115200 Bauds
Ethernet communication (optional)	Ethernet communication module enables transmission, management and maintenance of the sensors through an Ethernet network in 10 BASE-T and 100 BASE-TX LAN/WAN carrying the TCP/IP protocols Additional consumption: 0.68 VA
Visual alarm	Blinking of the value
Audible alarm	Buzzer (70 dB at 10 cm)
Environment and type of fluid	Air and neutral gases
Conditions of use (°C/%HR/m)	From -10 to +50°C. In non-condensing condition. From 0 to 2000 m.

TABLE OF THE PRE-PROGRAMMED UNITS

Domain	Unit
Temperature	°C, °F
Hygrometry	%HR, g/kg, Kj/Kg, °C td, °F td, °C Tw, °F Tw
Pressure	kPa, inWg, hPa, mbar, mmHg, mmH ₂ O, daPa, Pa
Air velocity	m/s, fpm, km/h
Air flow	m ³ /h, l/s, cfm, m ³ /s
Combustion	ppm
Electricity	mV, V, μ A, mA, A

INNOVATIONS

> Connection to a computer in front face

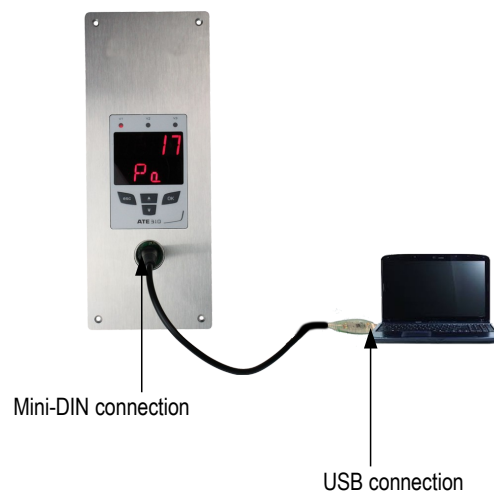

ALARMS

- The multi-channel display unit ATE310 has 3 visual and audible alarms independent and configurable. The available adjustments are:
- Time-delay duration: from 0 to 600 s
 - Acknowledgement duration: from 0 to 60 minutes
 - Thresholds values
 - Alarm triggering: rising edge, falling edge or monitoring
 - Audible alarm activation (buzzer)

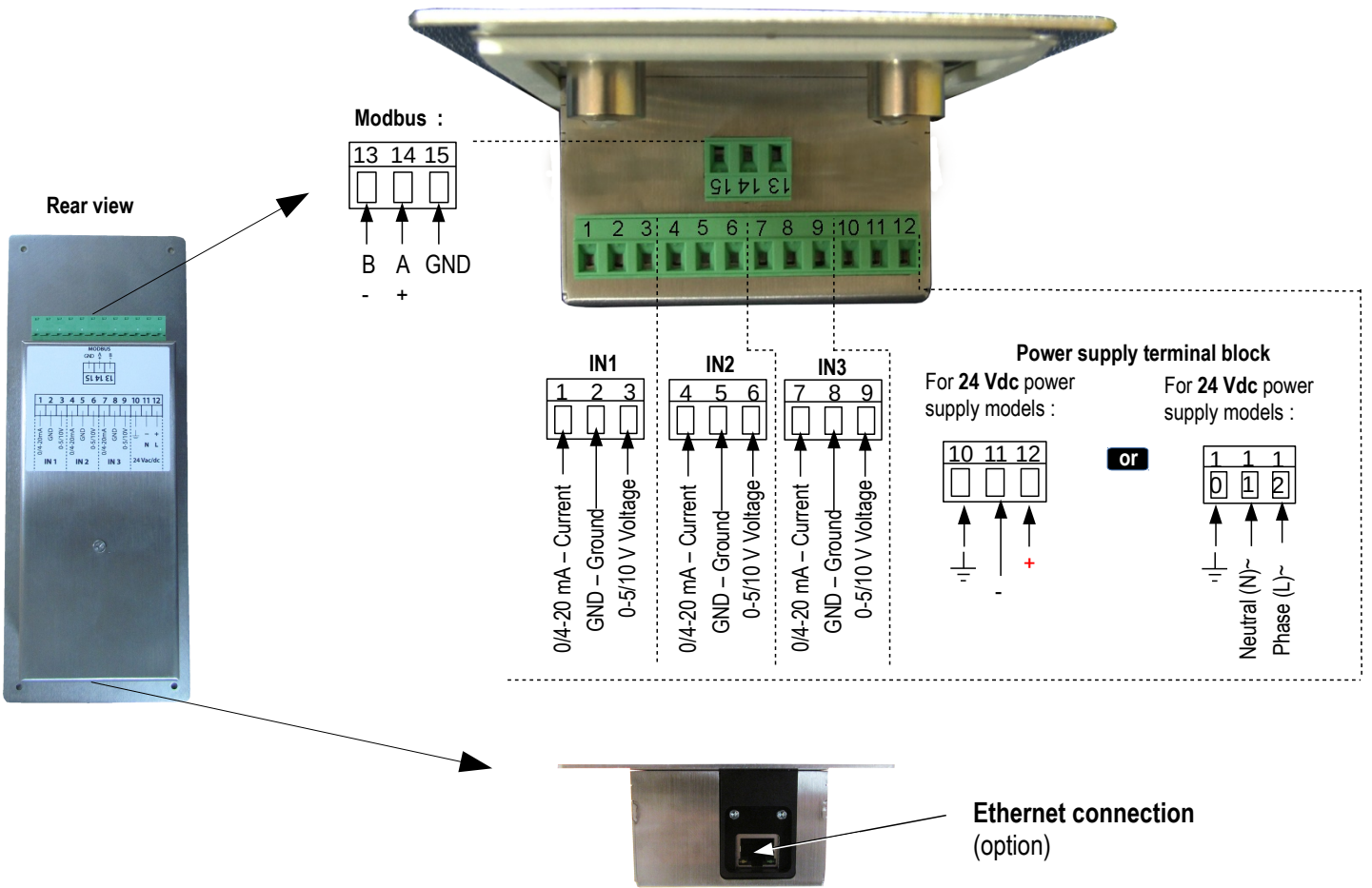

ELECTRICAL CONNECTION – as per *NFC15-100 standard*



Only a trained and qualified technician can realise this operation. To realise this connection, the device must NOT BE SUPPLIED.

> For 24 Vdc power supply models:

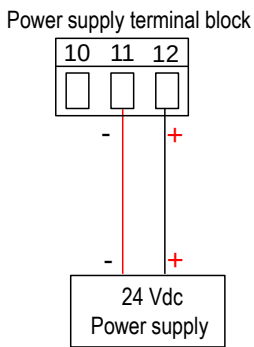

> For 24 Vac power supply models:

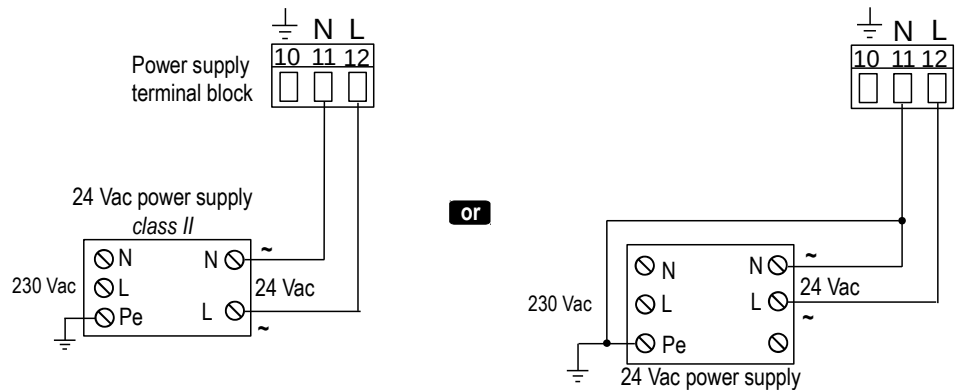

> Connection of the 0/4-20 mA current inputs:

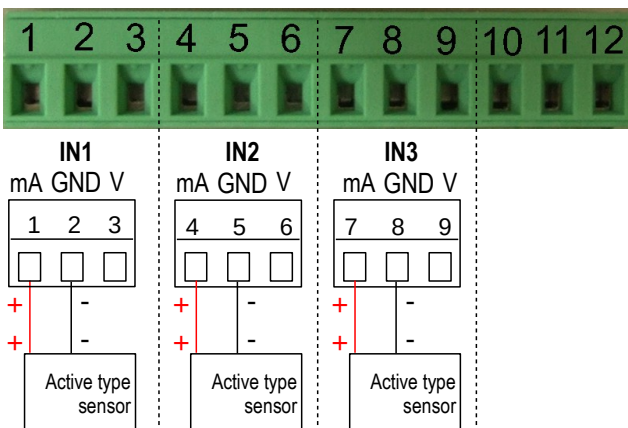

> Connection of the 0-5/10 V voltage inputs:

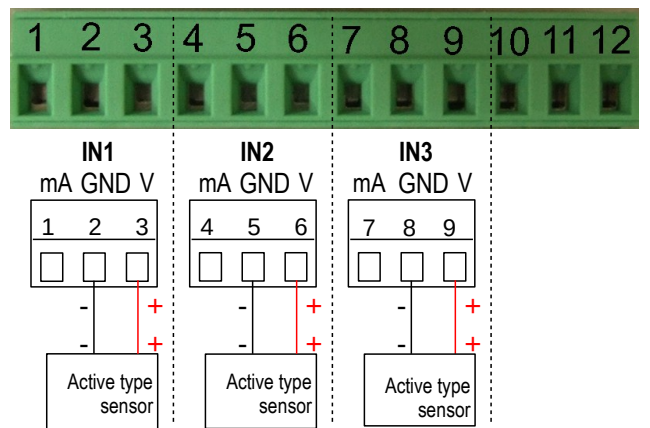

RS 485 MODBUS PROTOCOL

Class 310 transmitters can be linked in one network operating on a RS485 home bus.

The RS 485 digital communication is a 2-wire network, on which the transmitters are connected in parallel. They are connected to a PLC/BMS via the RTU Modbus communication system. Since the C310 can be configured with the keypad, the MODBUS enables remote configuration, to measure 1 or 2 parameters or to see the status of the alarms...

ETHERNET (OPTION)

An Ethernet board can be put on a ATE 310 transmitter allowing for each transmitter to have a specific configurable IP address. So the user can remotely interrogate the transmitter, retrieve data, modify the configuration, ...

It is also possible to integrate C310 transmitters into a computer network via the RJ45 connection located at the bottom of the transmitter.

CONFIGURATION

Class 310 transmitters allows you to set all the parameters managed by the transmitter: units, measuring ranges, alarms, outputs, channels... via the different methods shown below:

- > **Via keyboard:** a code-locking system for keypad guarantees the security of the installation. See configuration manual.
- > **Via software (option):** simple and user-friendly. See LCC-S software manual.
- > **Via Modbus:** configuration of all parameters from your PC via the supervision or data acquisition software.
- > **Via Ethernet (option):** configuration of all parameters from your PC via the supervision or data acquisition software.

MOUNTING

To install a transmitter on a wall, make a cutting in the wall of size 198 x 72 mm.

Then drill 4 holes around the cutting as shown beside. Insert the transmitter into the wall and fix it with the 4 screws supplied.

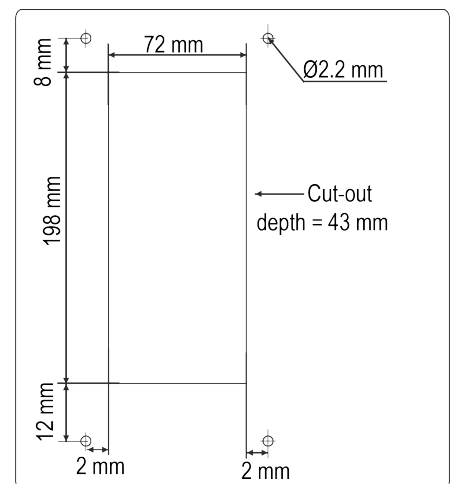

CALIBRATION

Outputs diagnostics: with this function, you can check with a multimeter (or on a regulator/display, or on a PLC/BMS) if the transmitter outputs work properly. The transmitter generates a voltage of 0 V, 5 V and 10 V or a current of 0 mA, 4 mA, 12 mA and 20 mA

Certificate: transmitters are supplied with an individual adjusting certificate and can be supplied with a calibration certificate as an option.

MAINTENANCE

Avoid aggressive solvents. When cleaning rooms or ducts with products containing formol, protect the the transmitter.

OPTIONS

- **LCC-S:** configuration software with USB cable
- **CETHE-2:** Ethernet
- Calibration certificate



Only the accessories supplied with the device must be used.

PRECAUTION FOR USE

Please always use the device in accordance with its intended use and within parameters described in the technical features in order not to compromise the protection ensured by the device.



Once returned to KIMO, required waste collection will be assured in the respect of the environment in accordance with European guidelines relating to WEEE.