

DATA SHEET

INCLINED LIQUID COLUMN MANOMETERS



MT 40

Pressure / Depression

The MT range of inclined liquid column portable manometers, developed and manufactured by Sauermann, are particularly recommended for those in the heating trade for checking pressures in chimney flues, combustion chambers, filters...



Easy to carry



Safety reservoir enabling momentaneous overshooting of the scale



Zero adjustment by moving the slide strip



Integrated spirit level for adjusting horizontality



Equipped with valve connectors, magnetic fixations, support with base plate



Can be used for air velocity measurement with Pitot tube

Measuring range

Reference	Measuring range (mm H ₂ O)		Sensitivity scale for 1 mm H ₂ O		Resolution	
	mm H ₂ O	daPa	For 1 mm H ₂ O	For 1 daPa	mm H ₂ O	daPa
MT 40	0 - 40	0 - 40	4 mm	4 mm	1 mm H ₂ O	1 daPa

Supplied with connecting sleeves, bottle of VOLT 1 S liquid and travelling case

General features

Recommended range of use	From +5 to +30 °C
Possible range of use	From -30 to +60 °C
Maximum static pressure	6 bars
Manometer body	Transparent 15 mm thick Altuglas
Liquid column	Entirely bored in the solid block, Ø 4 mm
Graduated slide strip	Transparent Altuglas. Cross-section 20 x 2 mm
Zero adjustment	By moving the graduated slide strip, travel 20 mm. Fixed via milled, nickel-plated brass screw
Positioning	Horizontal positioning via integrated spirit level and milled, nickel-plated brass adjusting screw, vertical travel 12 mm
Manometric liquid	VOLT 15 oil - density 1.86 at 20 °C
Reservoir capacity	20 ml
Connection	On valve connectors in nickel-plated brass Ø 6.2 mm neoprene tubes with connecting sleeves.

Dimensions

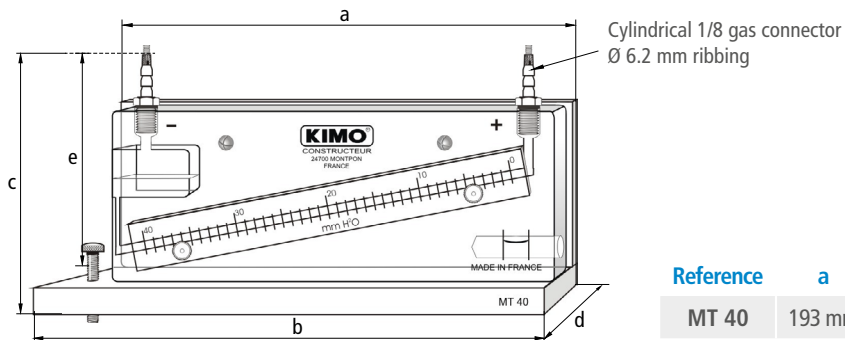

Reference	a	b	c	d	e	Weight
MT 40	193 mm	208 mm	93 mm	37 mm	80 mm	800 g

Mounting

1. Place the manometer on a horizontal surface or a vertical partition wall by using the magnetic fixations.
2. Set horizontality by using the integrated level and the milled adjusting screw.
3. Unscrew the connector on the reservoir and slacken the milled wheel on the other connector by one turn.
4. Slowly pour the manometric liquid to zero point on the graduation.
5. Remount the connector without overtightening.
6. Connect the manometer with the tube provided to the pressure or depression source to be checked.

Note:

For a pressure measurement: connect the crystal tube to the **right-hand connector (+)**

For a depression measurement: connect the crystal tube to the **left-hand connector (-)**

For a differential pressure: connect the highest pressure to the **right-hand connector (+)** and the lowest pressure to the **left hand connector (-)**

Maintenance: MT 40 manometer requires no special maintenance other than simply changing the reading liquid once a year.